



HOW TO INSTALL A C-SERT

Step 1



Drill out the damaged threads to the diameter shown on the C-Sert packaging, and slightly deeper than the length of the C-Sert.

Step 2

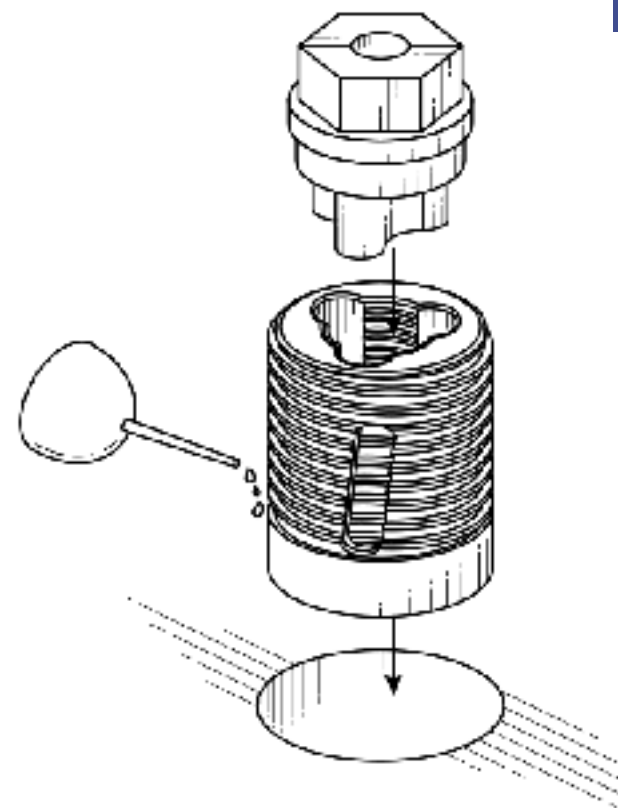

Apply plenty of cutting oil to the C-Sert and fit the hex-head installer into the top of the C-Sert.

Step 3

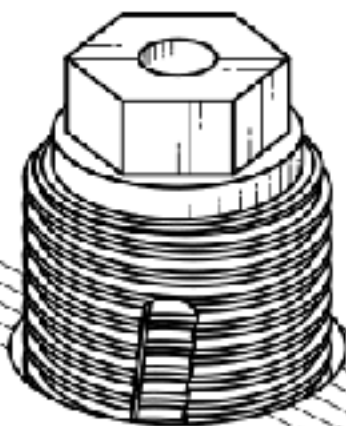

Put the C-Sert into the hole.

Step 4

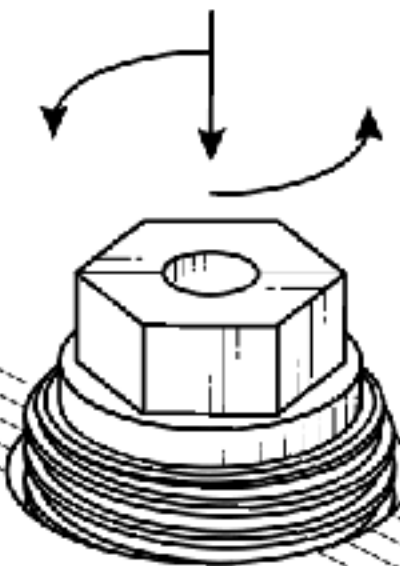

Use a long-handled ratchet to turn the C-Sert **COUNTER CLOCKWISE**. **Give the hex-head installer a couple of hits to seat the C-Sert fully in the hole.** Put some downward pressure on the ratchet as you turn it.

Step 5

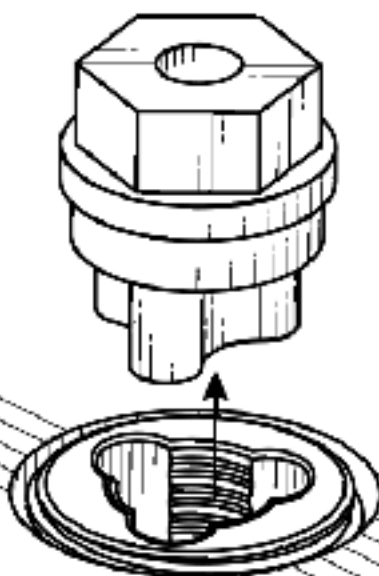

Once the top of the C-Sert is flush with the surface (or a bit below if you prefer), remove the installer, break up the chips inside the C-Sert, and blow them out.